

Installation Instructions for VAPRO Rupture Disks in VRDI Holder

TYPICAL VRDI INSTALLATION

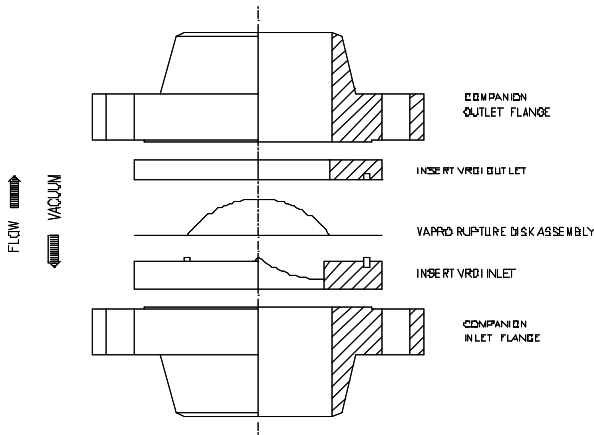

CAUTION

All rupture disk installations should be located to allow full unrestricted discharge of a burst disk when over pressure of the system occurs. Never locate a rupture disk assembly where the discharge from a burst disk can directly impact personnel or equipment. Venting of a burst disk discharge must always be routed to a safe disposal area. Handle burst rupture disks carefully! Avoid their sharp, jagged edges when removing same from holder. The knife blades in the VRDI holder are extremely sharp. Handle holders very carefully to avoid injury.

IMPORTANT

The VAPRO rupture disk assembly is a dual acting precision piece of equipment. Handle it with extreme care. Avoid scratching, bending, denting or damaging the dome and/or flat seat areas of the metal disk membrane. Handle the disk by the flat outer annular seating surfaces and avoid the dome area as much as possible. Never carry a VAPRO disk/holder assembly by the name tag alone as damage to the disk could occur. Do not place tools or foreign objects on top of the knife blades or

holder. The knife blades must be kept very sharp and free of nicks and defects in order for the disk assembly to function properly.

RUPTURE DISK HOLDER PREPARATION

- 1) Loosen and remove flange bolting only after verifying that the system is de-pressurized. Always purge toxic and/or dangerous materials area from any system that is to be opened to a safe disposal.
- 2) Slip the holder insert from between the companion piping flanges and place on a flat work surface. Verify that all holder restraints have been removed. Separate the holder inlet from the outlet and remove the existing rupture disk assembly.
- 3) Thoroughly inspect and clean all seating surfaces of the disk holder. Do **not** scrape or scratch any seating surface including the raised nubbin area! If wiping these surfaces with a clean cloth and a suitable solvent does not remove surface residues, fine emery cloth or steel wool may be utilized. Care should be exercised **not** to exert sufficient pressure on the emery cloth or steel wool to "cut or groove" these surfaces. When in doubt about the proper condition of these sealing surfaces, contact OSECO for further instructions.
- 4) Inspect knife blade points and edges. Knife blade edges must be razor sharp and free of nicks or defects. Points must be sharp and undamaged for the disk assembly to function properly. Contact OSECO for repair or replacement of dull or damaged knife blades.

Do not install the Assembly if the blades are dull, nicked or Damaged.

Installation Instructions for VAPRO Rupture Disks in VRDI Holder

RUPTURE DISK INSTALLATION

- 1) Carefully unpack the rupture disk from its box. If your disk assembly was packaged with a dome-shaped shipping protector marked "**SHIPPING PROTECTOR - DO NOT USE**", remove it now.
- 2) Place the Insert VRDI Inlet on flat work surface with the knife blades pointing up. Place the rupture disk assembly on the holder, carefully aligning the holes in the flange portion of the rupture disk assembly with the alignment pins in the VRDI inlet.
- 3) Position the Insert VRDI Outlet over the dome of the rupture disk assembly, carefully aligning the VRDI Inlet alignment pins with the holes in the VRDI Outlet. Lower the VRDI Outlet until it engages the VRDI Inlet alignment pins and rests on the flat outer annular seating surface of the rupture disk assembly. No binding should occur during this procedure. If interference occurs, discontinue installation until the source of the interference is determined and corrected.
- 4) Install side bars; however, cap screws should only be snug, **not** wrench tight.
- 5) Check companion flanges and verify that sealing surfaces are clean, free of corrosion and debris, and are not bent or warped.
- 6) Position the Vapro/VRDI assembly within the bolt circle of companion piping flanges. The concave side of the rupture disk assembly should face the process or possible vacuum source. Reinstall studs, nuts and suitable gaskets. Studs and nuts should be lightly oiled and free running.
- 7) Tighten each nut finger tight, then using a calibrated torque wrench, tighten each nut in a cross pattern. Use increments of 20% of the recommended torque value listed in the table below. Do not use torque values in excess of those shown in the Torque Table as this may damage the disk or the bite seal on the holder.

<i>VAPRO / VRDI TORQUE TABLE</i>					
SIZE		FLANGE RATING		RECOMMENDED TORQUE VALUE	
<i>IN.</i>	<i>mm</i>	<i>ANSI</i>	<i>DIN</i>	<i>Ft-Lb</i>	<i>N-M</i>
3	80	150	-	40	54
-	-	-	10/16	20	27
4	100	150	10/16	30	41
6	150	150	-	40	54
-	-	-	10/16	42	57
8	200	150	-	50	68
-	-	-	10	52	70
-	-	-	16	35	47
10	250	150	-	70	95
-	-	-	10	63	85
-	-	-	16	76	103
12	300	150	-	80	108
-	-	-	10	72	98
-	-	-	16	86	117