

Installation Instructions for FASS Rupture Disks in Sanitary Tubing Lines

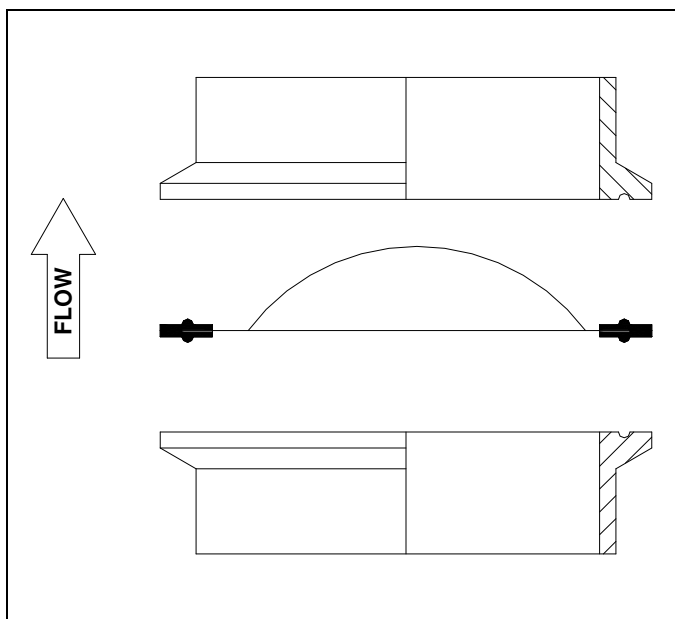

CAUTION

All rupture disk installations should be located to allow full unrestricted discharge of a burst disk when overpressure of the system occurs. Never locate a rupture disk installation where the discharge from a burst disk is directly impacting personnel or equipment. Venting of a rupture disk discharge must always be routed to a safe disposal area

IMPORTANT

A Forward Acting Scored Sanitary (FASS) rupture disk is a precision piece of equipment. Handle it with extreme care!! Avoid scratching, bending, denting or otherwise damaging the dome and/or flat seat areas of the disk. Handle the disk alone by grasping either the name tag or the flat outer sealing surfaces and avoid the dome areas as much as possible. **Never carry a FASS disk by the rupture disk name tag alone as damage to the disk could occur if handled in this manner.**

NEW RUPTURE DISK INSTALLATIONS

1) Loosen tubing joint sanitary clamp bolting at the tubing joint where the rupture disk is to be installed only after

verifying that the system is depressurized. Always purge toxic and/or dangerous materials from any system that is to be opened to a safe disposal area. Disk installation will require a space greater than the overall height of the FASS to insert the disk at any tubing system joint. Remove the sanitary joint clamp before attempting to provide the space required for installation.

2) Since this rupture disk has its own gasket mating the existing joint configuration, remove and discard the existing joint gasket once sufficient space is provided for the disk installation.

3) Thoroughly inspect and clean all seating surfaces within the opened tubing joint. Do **not** scrape or scratch any seating surface!! If wiping these surfaces with a “shop rag” moistened with a suitable solvent does not remove surface residues, special cleaning procedures beyond the scope of these instructions are required. Contact the appropriate end user personnel for instructions.

4) Verify that the system pressure will be exerted on the FASS disk cavity (concave side) and install disk such that the dome faces the vent system or atmospheric side. Verify that the gasket seats in the gasket grooves shown in the tubing joint flange detail.

5) Once the joint spacing created in 1) above has been closed, reinstall the tubing joint sanitary clamp. Torque the sanitary clamp bolting to the specifications of Table 1 below.

REPLACEMENT OF BURST DISKS:

Sanitary Joint Separation:

1) Loosen tubing joint sanitary clamp bolting at the tubing joint where the rupture disk is located only after verifying that the system is depressurized. Always purge toxic and/or dangerous materials from any system that is to be opened to a safe disposal area. Disk removal will require a space greater than the nominal disk size at the tubing system joint. Remove the sanitary joint clamp before attempting to provide the space required for removal of the burst disk assembly.

2) Once sufficient space has been provided for removal of

Installation Instructions for FASS Rupture Disks in Sanitary Tubing Lines

the burst disk, carefully extract the burst disk assembly. The points and edges of the four petals are sharp. Avoid these edges when handling the burst disk assembly!!

3) Thoroughly inspect and clean all seating surfaces within the opened tubing joint. Do **not** scrape or scratch any seating surface!! If wiping these surfaces with a “shop rag” moistened with a suitable solvent does not remove surface residues, special cleaning procedures beyond the scope of these instructions are required. Contact the appropriate end user personnel for instructions.

4) Verify that the system pressure will be exerted on the FASS disk cavity (concave side) and install disk such that the dome faces the vent system or atmospheric side. Verify that the gasket seats in the gasket grooves shown in the tubing joint flange detail.

5) Bend the narrow attachment structure to which the name tag is spot welded in such a manner that the flow arrow on the name tag is showing the correct flow direction, i.e., away from the pressurized system, toward the vent or relief system.

6) Once the joint spacing created in 1) above has been closed, reinstall the tubing joint sanitary clamp. Torque the sanitary clamp bolting to the specifications of Table 1 below.

HOLDER ASSEMBLIES OTHER THAN OSECO's

When installing OSECO's FASS rupture disk in a holder not manufactured by OSECO, please follow the procedure outlined above with regard to disk placement, care in handling the disk, etc. However, please consult the original installation instructions received with your holder for care, cleaning and inspection of your holder prior to returning it to service. This same document will also provide whatever special bolt procedures your holder may require. Please note that the non-OSECO holder must utilize the same gasket configuration or sealing will not occur.

Before **torquing** Sanitary Clamps to the values shown in the table below, check the PSI service rating of the clamp being used in Table II. Use Tri-Clover clamp (or equivalent) as shown to match the pressure of the system.

Clamp Size Inches	Torque In-lbs	Nominal Disk Size
1	20	1
1.5	20	1.5
2	20	2
3	20	3
4	30	4

Torque values are based on nuts and bolts being lightly lubricated and maintained in a “free running” condition.

Clamp Size Inches	Max PSI @ 72 °F	Max PSI @ 250 °F	Tri-Clover Clamp or Equivalent
1.0	500	300	13MHHM
	600	300	13MHHS
	1500	1200	13MHP
1.5	500	300	13MHHM
	600	300	13MHHS
	1500	1200	13MHP
2.0	450	300	13MHHM
	550	275	13MHHS
	1000	800	13MHP
3.0	350	195	13MHHM
	350	175	13MHHS
	1000	800	13MHP
4.0	350	195	13MHHM
	350	175	13MHHS
	1000	800	13MHP