

Installation Instructions for FMS Rupture Disks in Sanitary Tubing Fittings

TYPICAL INSTALLATION SHOWN

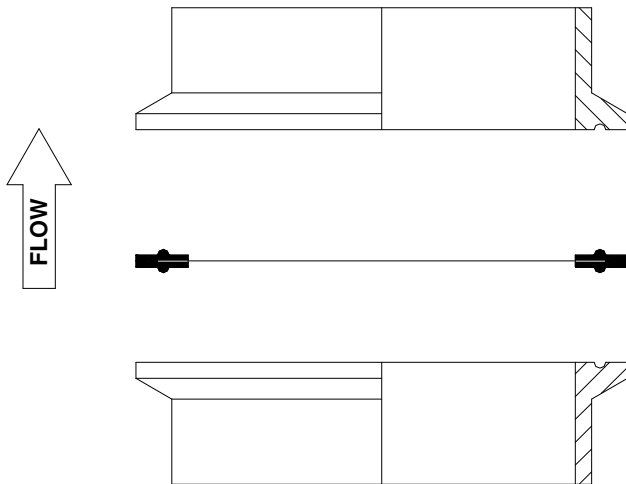

CAUTION

All new installations should be located to allow full unrestricted discharge when disks rupture occurs. Never locate a rupture disk installation where the discharge from a burst disk is directly impacting people or equipment. Handle burst rupture disks carefully! Avoid their sharp, jagged edges when removing same from a holder.

IMPORTANT

A FMS is a precision piece of equipment. Handle it with extreme care avoiding scratching, bending, denting or otherwise damaging the exposed surfaces of the disk. Handle the disk alone by grasping both the name tag and the outer gasket sealing surfaces and avoid the metal area as much as possible. Never carry a FMS disk by the rupture disk name tag alone as damage to the disk could occur.

NEW RUPTURE DISK INSTALLATIONS

Sanitary Joint Separation:

1) Loosen tubing joint sanitary clamp bolting at the tubing joint where the rupture disk is to be installed only after verifying that the system is depressurized. Always purge toxic and/or dangerous materials from any system that is to be opened to a safe disposal area. Disk installation will require a space greater than the overall height of the sanitary gasket into which the disk assembly is installed to insert the disk into the tubing system joint. Remove the sanitary joint clamp before attempting to provide the space required for installation.

2) Since this rupture disk has its own gasket mating the existing joint configuration, remove and discard the existing joint gasket once sufficient space is provided for the disk installation.

3) Thoroughly inspect and clean all mating surfaces within the joint. DO NOT scrape or scratch any seating surface!!! If wiping these surfaces with a "shop rag" moistened with a suitable solvent, does not remove surface residues, special cleaning procedures beyond the scope of these instructions are required. Contact the appropriate end user personnel for instructions.

4) The FMS is a bi-directional disk and may be installed so as to facilitate the greatest visibility of the name tag information. Verify that the gasket seats in the gasket grooves shown in the tubing joint detail.

REPLACEMENT OF BURST DISKS

Sanitary Joint Separation:

1) Loosen tubing joint sanitary clamp bolting at the tubing joint where the rupture disk is to be installed only after verifying that the system is depressurized. Always purge toxic and/or dangerous materials from any system that is to be opened to a safe disposal area. Disk installation will require a space greater than the overall height of the sanitary gasket into

Installation Instructions for FMS Rupture Disks in Sanitary Tubing Fittings

which the disk assembly is installed to insert the disk into the tubing system joint. Remove the sanitary joint clamp before attempting to provide the space required for installation.

2) Once sufficient space has been provided for removal of the burst disk, carefully extract and discard the burst assembly. The sharp edges can cause injury to personnel and should be avoided while handling.

3) Thoroughly inspect and clean all seating surfaces within the opened tubing joint. **DO NOT** scrape or scratch any seating surface!!! If wiping these surfaces with a "shop rag" moistened with a suitable, does not remove surface residues, special cleaning procedures beyond the scope of these instructions are required. Contact the appropriate end user personnel for instructions.

4) The FMS is a bi-directional disk and may be installed so as to facilitate the greatest visibility of the name tag information. Verify that the gasket seats in the gasket grooves shown in the tubing joint detail.

5) Once the joint spacing has been closed, reinstall the joint sanitary clamp.

Table II			
PSI Service Ratings			
Clamp Size Inches	Max PSI @ 72 °F	Max PSI @ 250 °F	Tri-Clover Clamp or Equivalent
1.0	500	300	13MHHM
	600	300	13MHHS
	3000	1200	13MHP
1.5	500	300	13MHHM
	600	300	13MHHS
	3000	1200	13MHP
2.0	450	300	13MHHM
	550	275	13MHHS
	2000	800	13MHP
3.0	350	195	13MHHM
	350	175	13MHHS
	1200	800	13MHP
4.0	300	150	13MHHM
	300	150	13MHHS
	1000	800	13MHP

Table I		
Sanitary Clamp Bolt Torque Requirements for FMS Rupture Disks		
Clamp Size Inches	Torque In-lbs	Nominal Disk Size
1	10	1
1.5	10	1.5
2	10	2
3	10	3
4	10	4

Torque values are based on nuts and bolts being lightly lubricated and maintained in a "free running" condition.